



Our main ingredient is value

VS2000

MADE IN USA

VS2000

# HIGH VOLUME VEGETABLE SLICER / SHREDDER

NOT FOR USE WITH CHEESE

Designed for high-volume vegetable slicing, the VS2000 makes short work of cabbage, lettuce, potatoes, onions and other vegetable slicing and shredding jobs.

A powerful 1HP motor drives the 9-inch Vegetable Slicer at 700 RPM via a rugged 1" wide Poly-V belt system. Standard front let extensions provide stability during heavy duty operation. Our VS9/VS9H housing of satin finish anodized aluminum with hinged feed chute door, latch and feed pusher comes standard with the VS2000. Equipped with a 9-inch "S" Knife Vegetable Slicer, and a Plate Holder ( Hub & Shaft) with a 5/16" Shredder Plate as standard equipment.

Engineered for years of trouble-free performance. The VS2000 is UL listed and NSF approved.



## WARRANTY

The Univex Vegetable VS2000 carries a one-year, on site warranty on parts and labor warranty against any flaws in materials and workmanship. This period begins with the date of purchase and, provided the unit is used properly in accordance with our instructions, is in full effect for one year from that date. Any work to be performed under this warranty must be performed between the hours of 8:00 a.m. and 5:00 p.m. local time, Monday through Friday. Univex will not pay overtime charges for work performed other than during normal business hours. Damages incurred in transit or from installation error, accident, alteration or misuse are not covered. Transit damages should be reported to the carrier immediately. Univex shall not be liable for any consequential, compensatory, incidental, or special damages. Contact Univex Service Department for any warranty claims.



UNIVEX CORPORATION ■ 3 Old Rockingham Road ■ Salem, NH 03079-2140  
Tel 603-893-6191 ■ Fax 603-893-1249 ■ E-mail [univex@univexcorp.com](mailto:univex@univexcorp.com)  
TOLL-FREE ORDERING FAX 1-800-356-5614  
[www.univexcorp.com](http://www.univexcorp.com)

April 2005  
Printed in USA

# HIGH VOLUME VEGETABLE SLICER / SHREDDER

VS2000

VS2000

## SPECIFICATIONS

- ELECTRICAL:** 115-230V, 60 HZ, Single Phase
- MOTOR:** 1 HP Capacitor start 1725 RPM, ball bearing motor on cushioned supports for reduction of both noise and vibration.
- SWITCH:** Rocker type double pole on-off conveniently located for access from the front or left side. Has a removable operator key to prevent unauthorized operation.
- CORD and PLUG:** 5 ft. (1524mm) long, 3-wire, 16 gauge SJTO cord with a polarized molded plug.
- DRIVE:** 2.5:1 Reduction increases torque using a 10 ribbed Poly "V" belt. 700 RPM drive shaft supported by ball bearings in the P.T.O. Housing.
- DRIVE ASSEMBLY:** Completely enclosed in an acrylic urethane silver enamel finished 10 gauge steel housing and No. 4 finish 20 gauge stainless steel cover.
- WEIGHT:** Net 85 lbs. (38Kg), Shipping 95 lbs. (43Kg).
- CUBE:** 5.8 cu ft (.16 cu m)

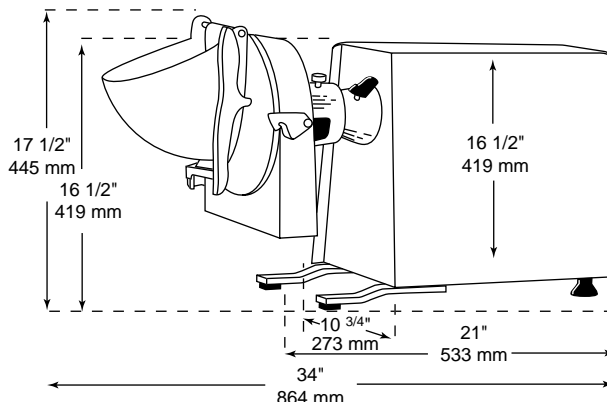

### STANDARD ATTACHMENTS:

#### PLATE HOLDER

5/16" Shredder Plate      Hub and Shaft Assembly (H and S)



#### STANDARD EQUIPMENT

- Die cast aluminum hub with stainless steel shaft and #12 rear hub and stainless locking pins.

#### OPTIONAL:

- 5/16" shredder plate
- Shredder Plates and Typical Uses:

Food Product	1/2" (13mm) ShredderPlate 000	5/16" (7mm) ShredderPlate 0	3/16" (4mm) ShredderPlate 3	3/32" (2mm) ShredderPlate 7
Cole Slaw	•	•		
Bread Crumbs		•		
Carrots for Coloring			•	•
Potatoes			•	

#### "S" KNIFE



#### STANDARD:

- Adjustable "S" knife assembly with hardened stainless steel knife and #12 rear hub

#### USED FOR SLICING:

- Lettuce
- Cucumbers
- Carrots
- Celery
- Radishes
- Cabbage
- Peppers
- Potatoes
- Chinese Vegetables
- Onions
- Zucchini



SINCE 1948

UNIVEX CORPORATION ■ 3 Old Rockingham Road ■ Salem, NH 03079-2140

Tel 603-893-6191 ■ Fax 603-893-1249 ■ E-mail univex@univexcorp.com

TOLL-FREE ORDERING FAX 1-800-356-5614

www.univexcorp.com

April 2005  
Printed in USA