



Our main ingredient is value

MG22

MADE IN THE USA

MG22

# MEAT & FOOD GRINDER

GRINDS UP TO 25 LBS PER MINUTE

NEW! NOW EQUIPPED WITH 1 H.P. MOTOR

Designed for high volume, heavy duty use with a #22 head, the MG22 will grind up to 25 lbs per minute. Driven by a 1hp gear motor, the grinding worm is directly coupled to the gear motor output shaft. Standard equipment includes a #22 grinder, 3/16" grinding plate, #22 knife, large 16" x 24" aluminum feed pan, plastic meat storage container, a feed stomper, and cleaning brush. The MG22 has a built in safety guard attached to the cast aluminum housing to prevent operator injury.



## WARRANTY

Model MG22 Meat & Food Grinder carries a one-year, on-site parts and labor warranty against any flaws in materials and workmanship. This period begins with the date of purchase and, provided the unit is used properly in accordance with our instructions, is in full effect for one year from that date. Any work to be performed under this warranty must be performed between the hours of 8:00 a.m. and 5:00 p.m. local time, Monday through Friday. Univex will not pay overtime charges for work performed other than during normal business hours. Damages incurred in transit or from installation error, accident, alteration or misuse are not covered. Transit damages should be reported to the carrier immediately. Univex shall not be liable for any consequential, compensatory, incidental, or special damages. Contact Univex Service Department for any warranty claims.



UNIVEX CORPORATION ■ 3 Old Rockingham Road ■ Salem, NH 03079-2140  
Tel 603-893-6191 ■ Fax 603-893-1249 ■ E-mail [univex@univexcorp.com](mailto:univex@univexcorp.com)  
TOLL-FREE ORDERING FAX 1-800-356-5614  
[www.univexcorp.com](http://www.univexcorp.com)

April 2005  
Printed in USA

# MEAT AND FOOD GRINDER

# MG22

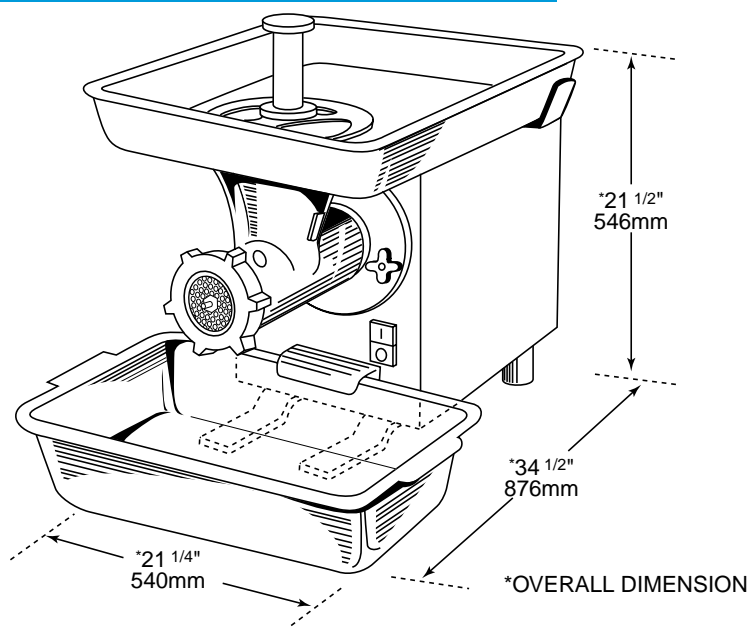

## SPECIFICATIONS

<b>ELECTRICAL:</b>	100 - 120V, 220 - 240V 50/60Hz, 1Ph
<b>MOTOR/ DRIVE:</b>	1HP Cycloidal, grease-packed gear motor provides compact, smooth and quiet performance with 8:1 reduction within the gear motor, resulting in 219 RPM drive shaft output. Grinding worm is directly driven by gear motor output shaft.
<b>DRIVE ASSEMBLY:</b>	Completely enclosed in an acrylic urethane silver enamel finished 10 gauge steel housing and a No. 4 finish 20 gauge stainless steel cover.
<b>SWITCH:</b>	Momentary contact stop and start push button /2 pole contactor provides no voltage release protection preventing accidental start up in the event of power interruption. Microswitch prevents operation of unit unless chopper is properly mounted.
<b>CORD &amp; PLUG:</b>	6 ft (1829mm) long, 3-wire 16 gauge SJTO cord with a polarized molded plug, NEMA 5-15P or NEMA 6-15P.
<b>MEAT GRINDER:</b>	Cast Aluminum housing, worm and ring. Housing is mounted onto the power base by two threaded studs and tightened on with two knobs. Housing has internal spiral flutes which match tapered flutes in the tapered worm. Flutes are designed to shear and force the product into the hardened steel knife and through the sizing holes of the plate. Designed to accept industry standard #22 plates and knives.
<b>FEED PAN:</b>	16" x 24" (406 x 610mm) Aluminum
<b>STORAGE CONTAINER:</b>	18 1/2" x 13 1/2" (470 x 343mm) plastic
<b>FEED STOMPER:</b>	Cast Aluminum designed for ease of handling and operator safety.
<b>CAPACITY:</b>	25 lbs (11.4kg) per minute on first grind using a plate with 3/16" (4mm) holes.
<b>WEIGHT:</b>	Net 112 lbs (51kg) Shipping 158 lbs (72kg) All parts are easy to remove for cleaning.
<b>BOX DIMENSIONS:</b>	29" (737mm) high, 24 1/2" (622mm) wide, 40" (1016mm) long.

