



Our main ingredient is value

4509, 4510 & 4512

4509, 4510 & 4512

PREP SAVER™ SLICER

LIGHT-DUTY — CHOICE OF 3 BLADE SIZES

Any way you slice it, PrepSaver™ slicers deliver big performance at a budget price. They're the ideal choice for many foodservice operations, owing to their compact footprint and value engineering.

Easy to operate, these manual, gravity-feed slicers offer a choice of 9", or 10" 12" cutting blades. They're the same German hollow-ground, chrome-plated, high carbon hardened steel blades found on high-end slicers. Slicing cheese is no problem. Unlike their competition, versatile PrepSaver slicers are engineered to handle cheese as well as meat and deli products.

The belt-driven blade is powered by a sturdy motor that will deliver years of dependable service. For operator safety, the prepSaver design features a permanent blade edge guard. There's also a convenient built-in sharpener and built-in meat holder.

Cleanup is easy, too, thanks to the removable carriage and smooth, polished anodized aluminum construction.

For your light-duty slicing needs, compact PrepSaver slicers are the best all-around decision you can make.

From Univex, the **cutting edge in value.**



- 9", 10" or 12" blade
- Compact footprint – 13 1/2" x 17"
- Manual operation, gravity-feed
- Belt driven
- Slice thickness up to 1/2"
- High carbon, hardened steel blade
- Permanent blade edge guard
- Polished anodized aluminum surfaces and slip grooves
- Built-in sharpener and meat holder
- Easy cleaning – removable carriage



WARRANTY

The Models 4509, 4510 & 4512 Slicer carry a one-year, carry-in parts and labor warranty against any flaws in materials and workmanship. This period begins with the date of purchase and, provided the unit is used properly in accordance with our instructions, is in full effect for one year from that date. Any work to be performed under this warranty must be performed between the hours of 8:00 a.m. and 5:00 p.m. local time, Monday through Friday. Univex will not pay overtime charges for work performed other than during normal business hours. Damages incurred in transit or from installation error, accident, alteration or misuse are not covered. Transit damages should be reported to the carrier immediately. Univex shall not be liable for any consequential, compensatory, incidental, or special damages. Contact Univex Service Department for any warranty claims.



UNIVEX CORPORATION ■ 3 Old Rockingham Road ■ Salem, NH 03079-2140
Tel 603-893-6191 ■ Fax 603-893-1249 ■ E-mail univex@univexcorp.com
TOLL-FREE ORDERING FAX 1-800-356-5614
www.univexcorp.com

April 2005
Printed in USA

PREP SAVER™ SLICER

4509, 4510 & 4512

4509, 4510 & 4512

LIGHT-DUTY CHOICE OF 3 BLADE SIZES

MODEL:	4509	4510	4512
INSTALLED: FOOTPRINT:	13 1/2" wide x 17" deep (343 x 432 mm)		
REQUIRED OPERATION AREA:	17" wide x 21" deep x 14 1/2" high (432 x 533 x 368 mm)	17" wide x 21" deep x 15" high (432 x 533 x 381 mm)	19" wide x 23 3/4" deep x 16" high (483 x 603 x 406mm)
NET WEIGHT:	39 lbs. (18kg)	40 lbs. (19 kg)	49 lbs. (23 kg)
SHIPPING WEIGHT:	45 lbs (21 kg)	46 lbs. (21 kg)	55 lbs. (25kg)
BOX:	20" wide x 24 " deep x 17 1/2" high (508 x 610 x 445 mm)		
CUBIC MEASURE:	4.9 ft 3 (0.14 m3)		

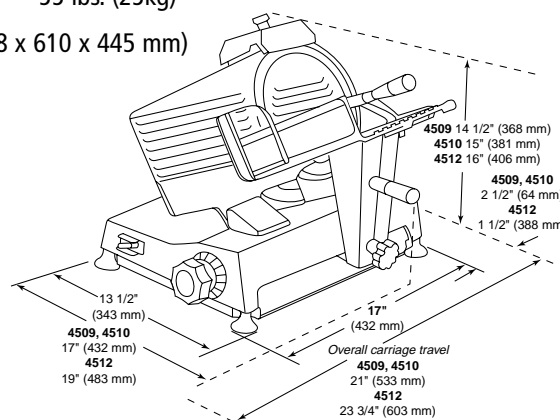

SPECIFICATIONS

MODEL:	4509	4510	4512
SLICE THICKNESS:	Infinitely variable, 0 to 1/2" (0 to 13mm)		
MAX. PRODUCT:			
SIZE:	Round 6 1/2" (165mm)	7 1/4" (184mm)	7 1/2" (191mm)
	Rectangular 6" (152mm) high, 8" (203mm) wide	6 1/2" (165mm) high, 8" (203mm) wide	6 1/4" (171mm) high, 10" (254mm) wide
CARRIAGE:	Stroke length 9" (229mm) Carriage length 9" (229mm)	9" (229mm) 9" (229mm)	12" (305mm) 11 1/4" (286mm)
BLADE:	German hollow-ground, chrome-plated carbon hardened steel. Belt driven.		
	9" (229mm), 425 rpm	10" (254mm), 425 rpm	12" (305mm), 374 rpm
MOTOR:	Capacitor start, capacitor run.		
	1/4 hp; 1.6 amp draw 1775 rpm	1/4 hp; 1.6 amp draw 1775 rpm	1/3 hp; 1.9 amp draw 1670 rpm
ELECTRICAL:	115 / 60 / 1-phase. Consult factory for special voltages.		
CONTROLS:	Manual operation. ON/OFF toggle switch. Slice thickness dial.		
CONSTRUCTION:	Polished anodized aluminum. Permanent blade edge guard. Built-in meat holder.		
HYGIENE / MAINTENANCE:	Removable carriage and circular blade guard. Built-in sharpener.		
RECOMMENDED MAXIMUM DUTY:	1 to 2 hours per day.		



UNIVEX CORPORATION ■ 3 Old Rockingham Road ■ Salem, NH 03079-2140
 Tel 603-893-6191 ■ Fax 603-893-1249 ■ E-mail univex@univexcorp.com
 TOLL-FREE ORDERING FAX 1-800-356-5614
www.univexcorp.com

April 2005
 Printed in USA