

Combination Vegetable Prep and Vertical Cutter-Mixer



- Fan-cooled, 3 HP three phase motor with magnetic safety switch. Push button “On-Off”, “High-Low” switch.
- Metal motor support with polycarbonate motor base.
- Large range of processing discs.
- Large feed pusher assembly and two deep feed openings on the continuous feed attachment.
- 5.5 Qt Stainless Steel Bowl attachment with stainless steel “S” blade.
- Attachments easily removed for superior cleanability.
- Unit base uses minimal counter space (14 1/4” x 14 1/2”).
- Standard package includes two processing discs (28064 & 28058) and one disc rack.
- 1 year parts and labor warranty.

Prepare 2000-plus servings
in 2½ to 3 hours

Vegetable prep attachment designed for quality continuous feed slicing, dicing, shredding, grating, french fry, and julienne. Accommodates 39 different processing discs. Bowl attachment designed for mixing, chopping, pureeing, and blending.



Robot Coupe U.S.A., Inc.
P.O. Box 16625
Jackson, MS 39236-6625
1-800-824-1646 • (601) 898-8411
FAX: (601) 898-9134
www.robotcoupeusa.com
e-mail: info@robotcoupeusa.com

SPECIFICATIONS ON REVERSE SIDE

Specifications

STANDARD MODEL: includes motor base unit, continuous feed attachment, discharge plate, one 1/8" (3mm) slicing disc, one 1/8" (3mm) medium grating disc and 5.5 Qt. stainless steel bowl with handle and stainless steel smooth edge "S" blade.

ELECTRICAL REQUIREMENTS: 208-240V, 60Hz, 2.6/2.8 Amps, three phase. NEMA L15-20P

SWITCHING: Control panel with push-type on and off buttons and latest type LOW-HIGH speed selector.

MOTOR: 3 HP, 850/1725 RPM, direct-drive, fan-cooled.

WEIGHT: 73 lbs. net, 74 lbs. approximate shipping weight.

OPTIONAL EQUIPMENT: 37 additional processing discs and single or multiple disc rack or wall-mounted disc rack.

STANDARDS: ETL electrical & sanitation, cETL (Canada)

PROCESSING DISCS

* For Series D machines only

Slicing Discs

28062	1/32" (1mm)
28063	5/64" (2mm)
28064	1/8" (3mm)
28004	5/32" (4mm)
28128*	3/16" (5mm)
28129*	5/16" (8mm)
28130*	3/8" (10mm)
28131*	9/16" (14mm)
28081	3/4" (19mm)
28132*	25/32" (20mm)
28133*	1" (25mm)

Grating Discs

28270	1/16" (1.5mm)
28057	5/64" (2mm)
28058	1/8" (3mm)
28073	5/32" (4mm)
28163	3/16" (5mm)
28164	9/32" (7mm)
28165	11/32" (9mm)
28055	Fine Pulping
28061	Hard Cheese Grate

Julienne Discs

28051	5/64" x 5/64" (2mm x 2mm)
27072	5/64" x 5/32" (2mm x 4mm)
27066	5/64" x 1/4" (2mm x 6mm)
27067	5/64" x 5/16" (2mm x 8mm)
28052	5/32" x 5/32" (4mm x 4mm)
28053	1/4" x 1/4" (6mm x 6mm)
28054	5/16" x 5/16" (8mm x 8mm)

Dicing Kits

28110	3/16" x 3/16" (5mm x 5mm)
28111	5/16" x 5/16" (8mm x 8mm)
28112	3/8" x 3/8" (10mm x 10mm)
28113	9/16" x 9/16" (14mm x 14mm)
28114	25/32" x 25/32" (20mm x 20mm)
28115	1" x 1" (25mm x 25mm)

French Fry Kits**

28134*	5/16" (8mm)
28135*	3/8" (10mm)

Ripple Cut Slicers

27068	5/64" (2mm)
27069	1/8" (3mm)
27070	3/16" (5mm)

Romaine Lettuce Kit

28133/104031	2"
--------------	----

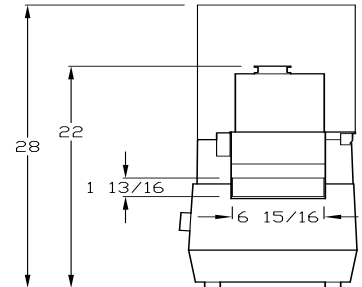
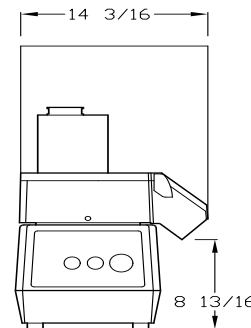
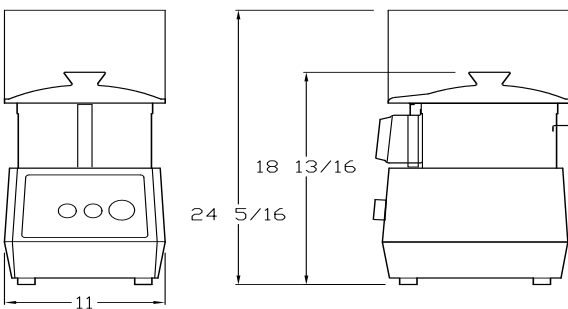
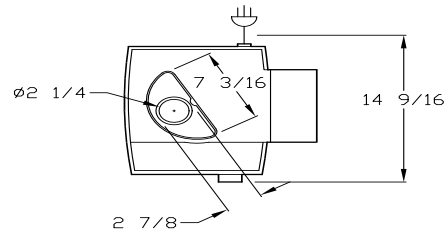
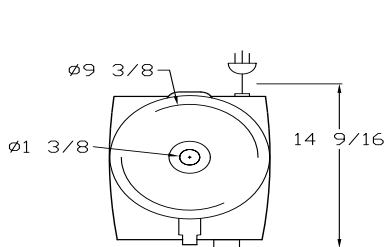

Robot Coupe U.S.A., Inc.
 P.O. Box 16625
 Jackson, MS 39236-6625
 1-800-824-1646
 (601) 898-8411
 FAX: (601) 898-9134
 www.robotcoupeusa.com
 e-mail: info@robotcoupeusa.com

Distributed by: