

# robot coupe

"The Inventor & World Leader in Food Processors"

"Series D"

## R301U Dice

Commercial Food Processor

### Combination Continuous Feed Vegetable Prep and Vertical Cutter Mixer



Prepare Sauces and  
Pate' in Bowl Unit

Vegetable prep attachment designed for quality continuous feed slicing, dicing, shredding, grating, french fry, and julienne cuts. Accommodates 21 different processing discs and two size french fry and dicing kits. Bowl attachment designed for vertical cutting and mixing functions: Mix, chop, puree, and blend.

- 2 H.P. single phase motor with magnetic safety switch. Push button "On-Off" and "Pulse" switches.
- New motor base and vegetable prep attachment designed to be more user friendly, better sanitation and made from new material that is more resistant to chemical agents for a longer life span.
- New 3.5 Qt. stainless steel cutter bowl and lid design with:
  - ergonomic handle for easier handling.
  - 10% increased liquid capacity due to higher hub.
  - new safety system improves the life span of lid and safety rod.
- New integrated ventilation system position for better sanitation.
- Great disc selection to accommodate most veg prep applications. Two French Fry and Dicing Kits to choose from.
- Attachments easily removed for assured sanitation.
- Unit base uses 13 1/16" x 11 15/16" of counter space.
- Packed with two processing discs and one dicing kit: 27577- 5/64" grating disc, 27566 - 5/32" slicing disc, and 27114 - 10mm dicing kit as standard.
- 1 year parts and labor warranty.



Robot Coupe U.S.A., Inc.

P.O. Box 16625

Jackson, MS 39236-6625

1-800-824-1646 • (601) 898-8411

FAX: (601) 898-9134

www.robotcoupeusa.com • e-mail: info@robotcoupeusa.

# R301U Dice

Commercial Food Processor

## Specifications

R301U DICE STANDARD MODEL: includes motor base unit with stainless steel cutter bowl, stainless steel "S" blade, continuous feed attachment, one 1/8" (3mm) slicing disc, one 1/8" (3mm) medium grating disc, one 10mm dicing kit and discharge plate.

ELECTRICAL REQUIREMENTS: 120V, 60Hz, 13 Amps, single phase. Contact your local electrician for local code requirements.

SWITCHING: Control panel with push-type on / off and pulse buttons.

MOTOR: 2 HP, 1725 RPM, direct-drive, fan-cooled.

WEIGHT: 43 lbs. net, 45 lbs. approximate shipping weight.

OPTIONAL EQUIPMENT: 19 additional processing discs, 2 french fry kits and 1 dicing kit.

STANDARDS: ETL electrical & sanitation, cETL (Canada)

## Available Disc Selection

### Slicing Discs

- 27051 - 1/32" (1mm)
- 27555 - 5/64" (2mm)
- 27086 - 1/8" (3mm)
- 27566 - 5/32" (4mm)
- 27087 - 3/16" (5mm)
- 27786 - 1/4" (6mm)

### Ripple Cut Slicers

- 27621 - 5/64" (2mm)

### Graters

- 27588 - 1/16" (1.5mm)
- 27577 - 5/64" (2mm)
- 27511 - 1/8" (3mm)
- 27046 - 1/4" (6mm)
- 27632 - 11/32" (9mm)
- 27078 - Hard Cheese Grate

### Pulping

- 27079 - Fine pulping disc
- 27764 - Pulping disc

### Julienne

- 27599 - 5/64" (2x2mm)
- 27080 - 5/64" x 5/32" (2x4mm)
- 27081 - 5/64"x1/4" (2x6mm)
- 27047 - 5/32" (4x4mm)
- 27610 - 1/4" (6x6mm)
- 27048 - 5/16" (8x8mm)

### French Fry Kits

- 27116 - 8x8 mm (5/16")
- 27117 - 10x10mm (3/8")

### Dicing Kits

- 27113 - 8x8 mm (5/16")
- 27114 - 10x10mm (3/8")

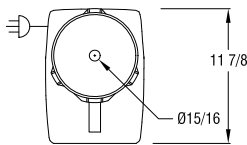

Cutter Bowl

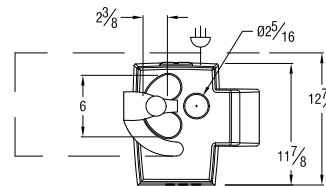

Veg Prep

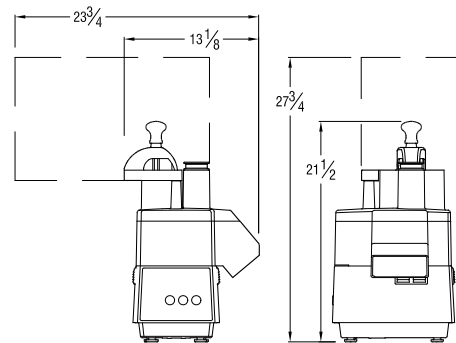
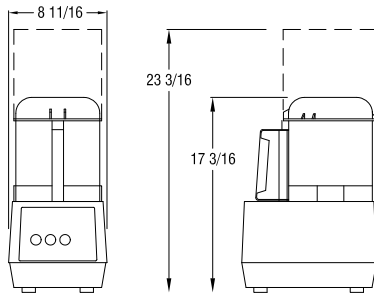

Robot Coupe U.S.A., Inc.

P.O. Box 16625

Jackson, MS 39236-6625

1-800-824-1646

(601) 898-8411

FAX: (601) 898-9134

www.robotcoupeusa.com

e-mail: info@robotcoupeusa.com

## Distributed by: